

All Harrod UK 5-A-Side Football Goals conform to the BS 8462:2005 Standard.

Important Note:

All freestanding goals **MUST** be anchored at **ALL** times. Harrod UK recommend that two ground anchors must be applied to all freestanding football goals to conform to the applicable BS EN 748:2004 or BS 8462:2005 standard.

It is essential to conduct a risk assessment of your particular site to evaluate the suitability of specific types of anchorage.

Please see ground anchor instruction number INS535 for available anchors.

Use of Counterbalance weights - Counterbalance weights are an effective method of stabilising goal posts, but care should be taken to ensure the correct amount of weight is used:

✂ 5-A-Side Freestanding Football Goals need 105kg of weight (6 x ANC-005)

PLEASE READ ALL OF THE INSTRUCTIONS FOR YOUR GOAL BEFORE YOU BEGIN ASSEMBLY.

Greasing

To increase the life of your goal you should grease all crossbar joints and moving parts.

Waterproof instructions are available on request

FS1 Foldaway Steel Goal (Patent No GB9502230.7).

Portable, Folding free-standing, with mitred crossbar joints. Made from 50.8mm diameter steel with 25.4mm diameter net supports.

Assembly

If a net is to be fitted, it is a good idea to thread the crossbar through the net before assembly.

Each person should hold one sideframe and one end of the crossbar. The crossbar can then be lowered onto the sideframe until the button clip engages in one of the two holes.

The Back Bar should now be inserted into the collar on the back of each side frame. Depress the button clip to engage into the hole in the collar.

Please Note: Initial assembly may require some force to fit the side frame into the crossbar. This is normal and is necessary so that when the paint wears off internally over time from folding, the stability of the goal is not compromised.

Operation

To fold the goal, simply depress the button clip and fold the sideframe until the button clip locates in the other hole.

Do not lift the crossbar when the button clip is disengaged from one of the two holes - this is not necessary and may cause the crossbar to lift off the sideframe and the goal to collapse.

Important

Do not try to fold the goal when the button clips are engaged. This could break the clips and damage the frame.

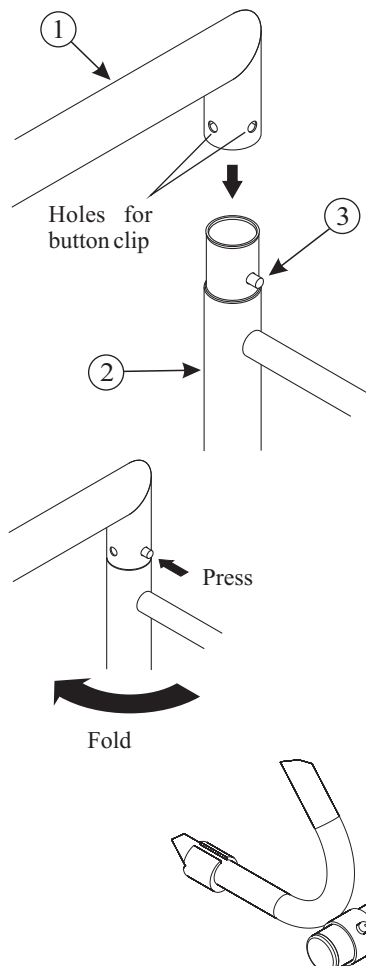

FBL-036 4.88x1.2m Components

- 1 x Crossbar (pair). (FEQ200)
- 1 x Sideframe (set of 4). (FEQ203)
- 4 x Button Clip (pre-fitted). (SPR107)
- 1 x Back Bar (pair). (FEP625)

FBL-037 3.66x1.2m Components

- 1 x Crossbar (pair). (FEQ201)
- 1 x Sideframe (set of 4). (FEQ203)
- 4 x Button Clip (pre-fitted). (SPR107)
- 1 x Back Bar (pair). (FEP626)

FBL-038 2.44x1.2m Components

- 1 x Crossbar (pair). (FEQ202)
- 1 x Sideframe (set of 4). (FEQ203)
- 4 x Button Clip (pre-fitted). (SPR107)
- 1 x Backbar (pair). (FEP627)

Assembly Requirements

Number of People: 2
Time to Assemble: 3 minutes
Tools Needed: None

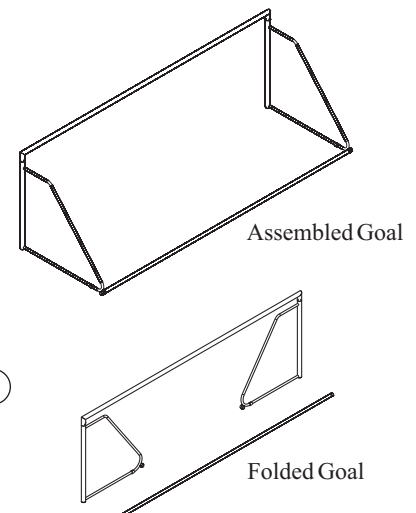

Code:

Product: 5-Aside Steel Football Goals

FS5 Socketed Steel Goal.

Made from 50.8mm diameter heavy steel with 31.8mm diameter fully welded sideframes with sockets.

Assembly

Prepare the ground so that you have a trench approx 516mm deep, 1566 long and wide enough at each end to pour a 476mm cube of concrete. Position the sockets in the trench and pack so that the top of the socket is level with the finished ground level. To ensure an accurate positioning of the sockets assemble and sit the goal in the sockets before pouring the concrete (If the goal is not available to do this then use the upright centres given below).

Always use a spirit level on the uprights and crossbar to ensure that the goal is installed true. Allow at least 24 hours for the concrete to set before use.

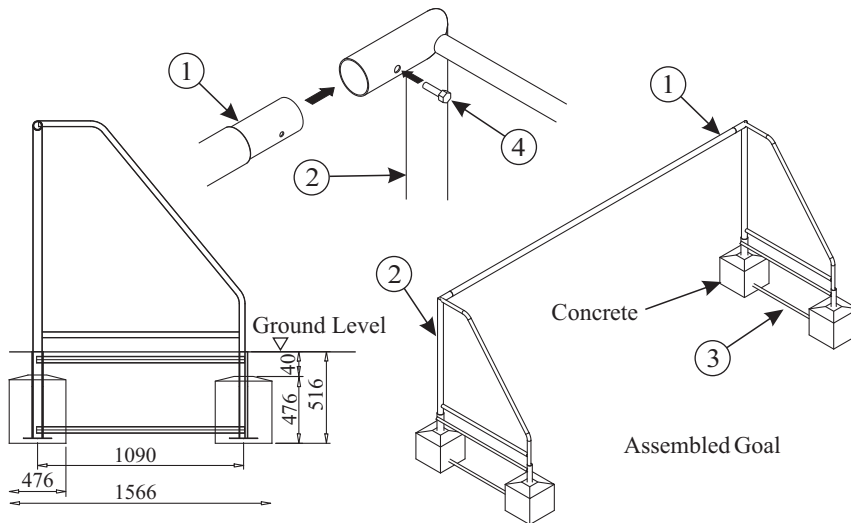

FBL-131 4.88x1.2m Components

1. 1 x Crossbar (*pair*). (FEQ228)
2. 2 x Sideframe (*pair*). (FEQ223)
3. 2 x Socket (*pair*). (FEQ224)
4. 4 x M8 Bolt (*pre-fitted*). (BOL530)

FBL-132 3.66x1.2m Components

1. 1 x Crossbar (*pair*). (FEQ229)
2. 2 x Sideframe (*pair*). (FEQ223)
3. 2 x Socket (*pair*). (FEQ224)
4. 4 x M8 Bolt (*pre-fitted*). (BOL530)

FBL-133 2.44x1.2m Components

1. 1 x Crossbar (*pair*). (FEQ230)
2. 2 x Sideframe (*pair*). (FEQ223)
3. 2 x Socket (*pair*). (FEQ224)
4. 4 x M8 Bolt (*pre-fitted*). (BOL530)

Assembly Requirements

Number of People: 2
Time to Assemble: 2 hours
Tools Needed: 1xSpade
Concrete Mixer
Spirit Level

Upright Centre

FBL-131 4931mm Centres
FBL-132 3714mm Centres
FBL-133 2490mm Centres

FS6 Permanent Steel Goal.

Made from 50.8mm diameter heavy duty steel with 31.8mm diameter fully welded sideframes which are cemented into the ground.

Assembly

Prepare the ground so that you have a trench approx 516mm deep, 1558 long and wide enough at each end to pour a 476mm cube of concrete. Assemble the goal, position it in the trench and pack so that the underside of the crossbar measures 1.22m from finished ground level.

Using a spirit level on the uprights and crossbar, ensure that the goal is installed true and then pour the concrete. Allow at least 24 hours for the concrete to set before use.

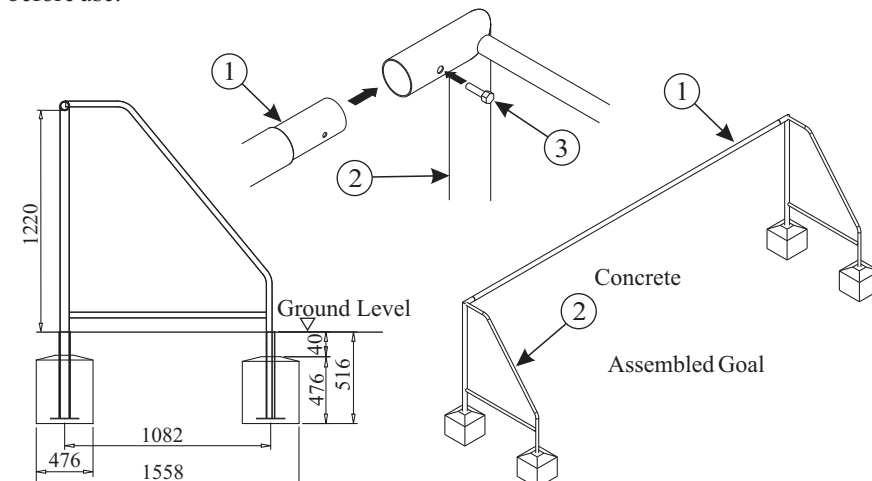

FBL-134 4.88x1.2m Components

1. 1 x Crossbar (*pair*). (FEQ228)
2. 2 x Sideframe (*pair*). (FEQ226)
3. 4 x M8 Bolt (*pre-fitted*). (BOL530)

FBL-135 3.66x1.2m Components

1. 1 x Crossbar (*pair*). (FEQ229)
2. 2 x Sideframe (*pair*). (FEQ226)
3. 4 x M8 Bolt (*pre-fitted*). (BOL530)

FBL-136 2.44x1.2m Components

1. 1 x Crossbar (*pair*). (FEQ230)
2. 2 x Sideframe (*pair*). (FEQ226)
3. 4 x M8 Bolt (*pre-fitted*). (BOL530)

Assembly Requirements

Number of People: 2
Time to Assemble: 2 hours
Tools Needed: 1xSpade
Concrete Mixer
Spirit Level

Upright Centre

FBL-134 4931mm Centres
FBL-135 3714mm Centres
FBL-136 2490mm Centres

Code:

Product: 5-Aside Steel Football Goals

FS8 Folding Wheel-Away Steel Goal.

Made from 50.8mm diameter heavy duty steel with 31.8mm diameter folding sideframes and flip-over wheels.

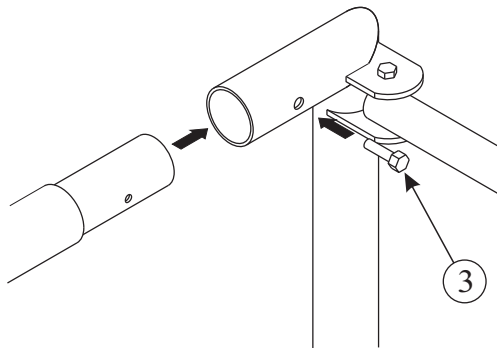

Assembly

Remove the pre-fitted bolts from the crossbar. If a net is to be fitted, it is a good idea to thread the crossbar through the net before assembly.

Each person should hold one sideframe and one end of the crossbar. Insert the ends of the crossbar into a sideframe elbow and secure with the bolts.

If the Back Bar has been supplied in 2 halves; join together as shown below, by depressing the button clip and insert the smaller tube into the open end.

The Back Bar should now be inserted into the collar on the back of each side frame. Depress the button clip to engage into the hole in the collar.

FBL-125 4.88x1.2m Components

1. 1 x Crossbar (*pair*). (FEQ228)
2. 2 x Sideframe (*pair*). (FEQ100)
3. 4 x M8 Bolt (*pre-fitted*). (BOL530)
4. 1 x Backbars (*pair*). (FEP752)

FBL-126 3.66x1.2m Components

1. 1 x Crossbar (*pair*). (FEQ229)
2. 2 x Sideframe (*pair*). (FEQ100)
3. 4 x M8 Bolt (*pre-fitted*). (BOL530)
4. 1 x Backbars (*pair*). (FEP753)

FBL-127 2.44x1.2m Components

1. 1 x Crossbar (*pair*). (FEQ230)
2. 2 x Sideframe (*pair*). (FEQ100)
3. 4 x M8 Bolt (*pre-fitted*). (BOL530)
4. 1 x Backbars (*pair*). (FEP754)

Assembly Requirements

Number of People: 2
Time to Assemble: 5 minutes
Tools Needed: 1x13mm Spanner

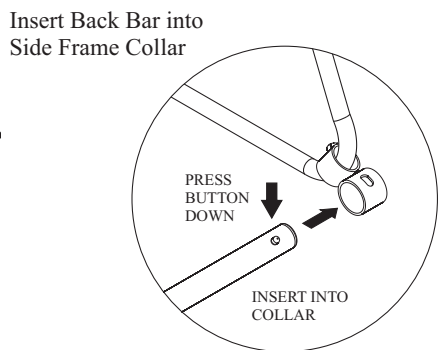
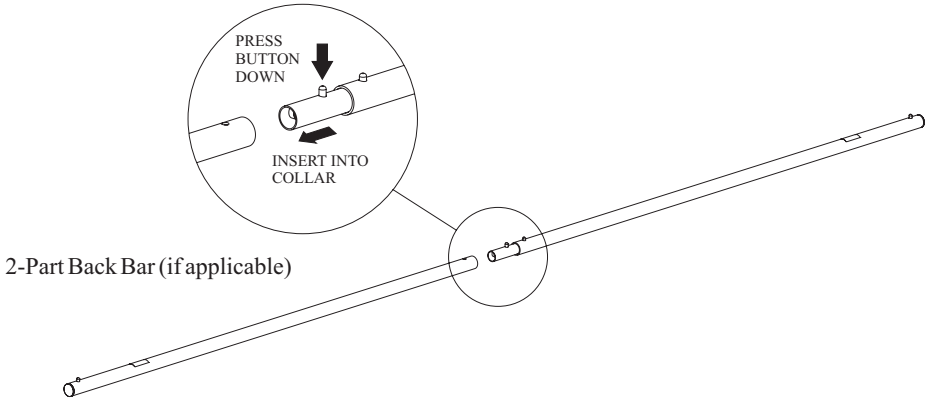

Folding The Goal

To fold the goal press down on the sideframe near the wheel with your foot and fold until the side frame tube locks in place. This must be done by 2 people.

Operating the Wheel

Lift the upright and flip the wheel into position.

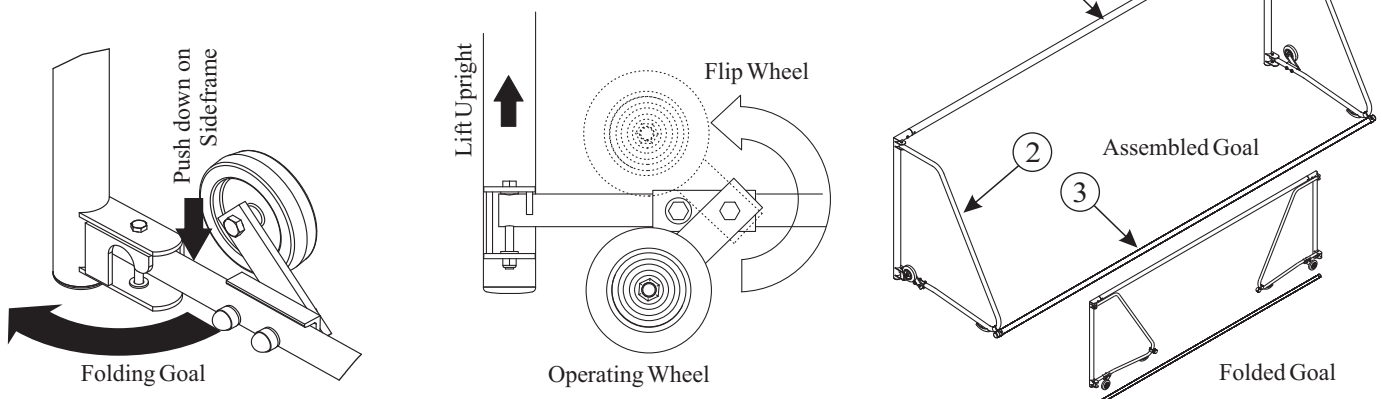

GENERAL OPERATION & MAINTENANCE GUIDE RECOMMENDATIONS FOR SPORTS GROUND EQUIPMENT

It is the responsibility of the facility operator to provide equipment that is fit for purpose and maintained to the required standard.

Operators also have a responsibility to staff under the Health & Safety at Work Act to ensure that staff are properly trained to carry out the required tasks for which they are employed. It is the facility providers who could find themselves liable in the case of any accidents where staff are found not to be competent.

Assembly & Dismantling

1. When assembling equipment, always refer to the instructions and recommendations provided by the manufacturer.
2. We remind you that the appropriate personal protective equipment (PPE) must be worn at all times. e.g. hard hat, safety boots, gloves etc.
3. When tall and/or heavy equipment is being erected, it is recommended that scaffolding and/or heavy lifting equipment is used. A risk assessment should be carried out by the facility provider, if necessary.
4. The correct tools for the job must be used at all times.
5. Assembly must be carried out by a sufficient number of competent persons as outlined by the manufacturer's instructions

Checking Equipment

Equipment should be checked on a regular basis. This requires positive action, and the information gathered must be recorded and acted upon immediately should any faults be found.

1. Check all equipment a minimum of once every week - but always before any game or training activity.
2. Carry out a thorough visual check of the whole goal. Check that all fixings are secure and there are no loose or missing nuts, bolts, pins or other fixings.
3. If any nuts, bolts, pins or other fixings are missing, it is not possible to assemble the equipment correctly. It is therefore vital that missing parts are purchased from the manufacturer to ensure compatibility.
4. If parts of the goal are bent or other damage is present, there may be more damage internally which is not visible and could result in the goal collapsing or tipping. The goal should be taken out of action and removed from site whilst replacement parts are ordered.
5. Check that all pivot points are in good condition and lubricated with grease.
6. Any chips or scratches must be treated to prevent corrosion occurring at these points. Maintenance kits are available through your distributor.
7. Check all anchoring attachments and anchoring points.
8. Should weight type anchors be used, check there are the correct number as outlined in the manufacturer's instructions for the size of the goal.
9. If you find a fault, you must record the fault and do not continue to use the goal. It must be correctly repaired or replaced with new equipment.
10. Do not modify goals by welding or by substituting with incorrect parts.

11. Wheel mechanisms should be complete and in full working order.
12. Inflatable tyres must be checked for punctures and be inflated to no more than the maximum pressure marked on the tyre.
13. Cellular or solid type wheels are the preferred option as little maintenance is required.

Checking Netting

1. Check for missing or broken net fixings as these may allow a ball to pass between the edge of the net and goal frame, resulting in confusion over whether a goal has been scored or not.
2. The size of the mesh of the net has been chosen to reduce the risk of injury caused by entrapment. If there are broken cords, the holes become larger than intended and will require repairing or replacing.
3. Any broken cord in the nets may be able to be repaired using the same cord used to manufacture the net.
4. Replace nets when damage prevents correct functionality.
5. Nets must be stored out of direct sunlight and away from rodents.

The Code of Practice provided by BS 8461 gives guidance as to the type of checks that should be carried out on football goals and how often they should be done. Although this is football specific, it is widely considered best practice for all sports.

Storage

1. Our instructions (INS535) regarding anchoring must still be adhered to when freestanding products are stored assembled.
2. If equipment has folding back supports, it is recommended that the posts are stored flat on the ground. If they are required to be stored vertically, e.g. leant against a fence, they must be attached in such a way as to prevent them falling over.
3. When dismantled, parts must be stored safely & securely in order to prevent accidents in the storage area.

Moving

1. Great care must be taken in moving the product whilst it is still assembled.
2. If no transportation wheels are provided, equipment must be lifted by a sufficient number of competent persons, as stated in the assembly instructions, to prevent injury or damage to the product.
3. Equipment should never be dragged across the ground. Moving equipment in this way is likely to cause damage to both the product and the surface, whether natural or synthetic. Equipment must be lifted clear off the ground when it is being moved.
4. If additional weights are fitted to the goal, they must be removed first before attempting to move the goal. Once the goal is in position, carry the weights to the goal and reattach.
5. Where goals with specific folding mechanisms are used, care must be taken to fold in accordance with both the instructions and product labels. Damage can often occur when mechanisms are not released in the correct manner. Always refer to the instructions and product labels.

Keeping Records

1. The safety of equipment is the responsibility of both the facility providers (who should provide safe goals, installed and maintained in a safe condition) and the users (who should only use the equipment for it's intended purpose).
2. Facility providers should be aware of operation and maintenance guidelines and keep records of all checks, installations and maintenance carried out.

Example 1 - Goal Record Sheet

GOAL RECORD SHEET

Goal Reference	Pitch 3 North End			
				
Date	Type of check	Findings	Action taken	Checked by
10th Dec 2016	Weekly	Scratched paintwork on left hand upright	Painted over required area. Used Harrod UK white touch up paint	Harry Pitts
18th Dec 2016	Weekly	All ok	None	Harry Pitts
2nd Jan 2017	Full	Goal passed Strength & Stability tests - no other problems	Full goal post risk assessment undertaken	Harry Pitts
10th Jan 2017	Weekly	Goal net has holes and broken meshes, some net hooks also missing	Purchased new net and clips and fitted to goal	Harry Pitts

Example 2 - Goal Inspection Sheet

GOAL INSPECTION SHEET

				
Site	Walmer Road	Pitch No.	3	
Goal Reference	Pitch 3 North End	Type of Goal	Socketed Aluminium	
Size of Goal	7.32 x 2.44m	Stability Test Pass	Yes / No	
Strength Test	notes:	Start Height	mm	
		Finish Height	mm	
		Deflection Test (>10mm = fail)	mm Pass / Fail	
Supplier/Manufacturer	Harrod UK Ltd	Date of Manufacture	Feb-16	
Inspected By	Harry Pitts	Date of Inspection	10th Jan 2017	
Findings	Goal net has holes and broken meshes, some net hooks also missing			
Action Taken	Purchased new net and clips and fitted to goal			
Contact details for spares and repairs	Harrod UK Ltd, Pinbush Road, Lowestoft, Suffolk, NR33 7NL Tel: 01502 583515, Email: sales@harrod.uk.com			

GUIDELINES FOR SPECIFIC SPORTS

Football

1. Goals should always be installed in accordance with the manufacturer's instructions.
2. Installation should only be undertaken by, or under the direct supervision of, trained persons with enough experience and with adequate assistance for the size of the goal being erected. Please refer to the manufacturer's instructions for the number of persons required.
3. **Socketed goals** should always be set in concrete. The dimensions of the concrete foundations should be in accordance with the manufacturer's instructions for the prevailing ground conditions and equal to or in excess of the minimum dimensions given in BS EN 748 for full-size goals, or BS 8462 for all other types of goal.
4. **Freestanding goals** are only safe if they are properly stabilised in accordance with the manufacturer's instructions. Stabilising and anchoring systems should always be used. INS535 provides installation and assembly information for all available systems.

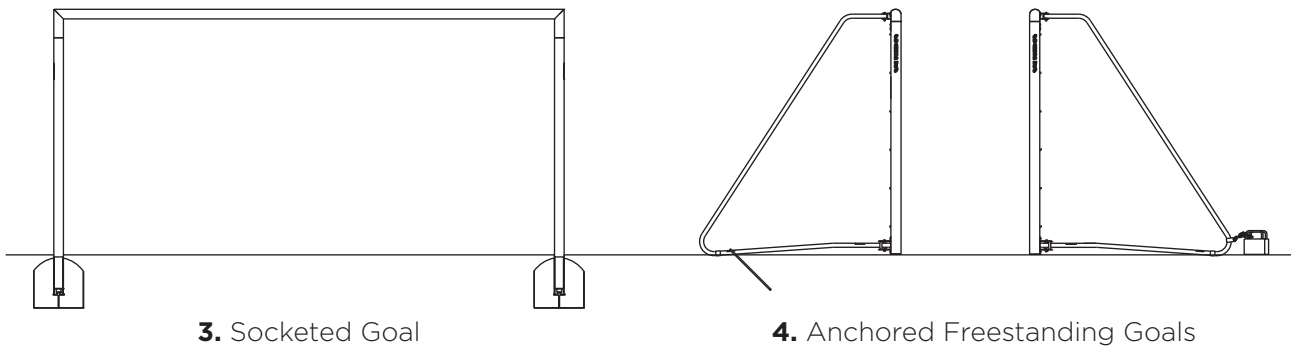

5. Goals fitted with wheels should be moved using four competent persons, one in each corner of the frame and in the correct manner as stated in the assembly instructions.
6. Four competent persons must be used to move **Integrally Weighted Goals**, as per standard wheeled goals. It is important to check that the handle and wheel are locked in the raised position before attempting to move the goal.
7. **Fence Folding Goals**, with socketed support posts, are designed to be manoeuvred simultaneously by 2 competent persons. Care must be taken whilst moving the goal to ensure the net does not become entangled.
8. **Freestanding Folding Goals** require two competent persons to fold, lift and move the goals

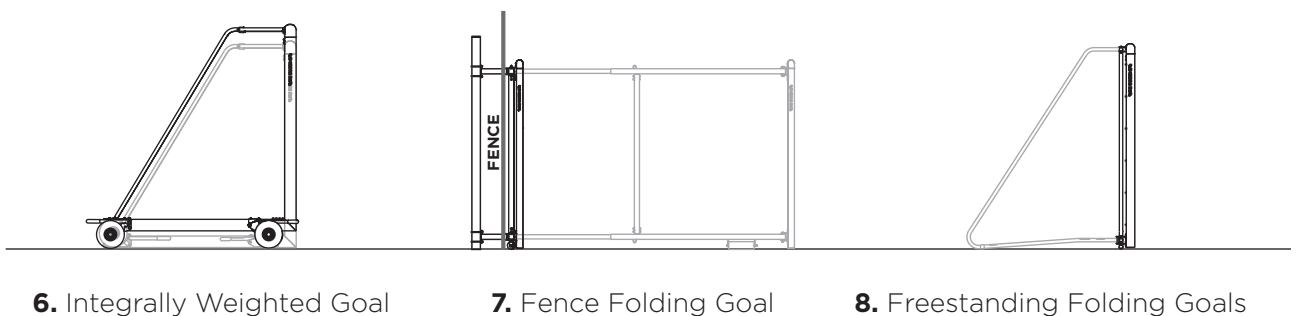

Rugby

1. Ensure the correct amount of concrete is in place for the sockets before assembling posts. Please refer to your product assembly instructions to find the amount of concrete required.
2. Allow a minimum of 3 people to allow safe erection of all Rugby posts.
3. Always erect one upright at a time and ensure the crossbar is removed before taking the posts down.
4. **Hinged Rugby Posts** can be used with a **Rugby Lifter** and small tractor to ensure quick and safe erection. This allows for maintenance to be easily carried out mid-season if required.
5. **Socketed Rugby Posts** are erected by inserting them into a socket in the ground which has been securely cemented in place. Due to the nature of Socketed Rugby Posts, they are more difficult to put up and take down than Hinged Posts, therefore, maintenance is best carried out at the end of season.
6. If possible, remove and store posts between matches, but posts are normally left erected for the season.

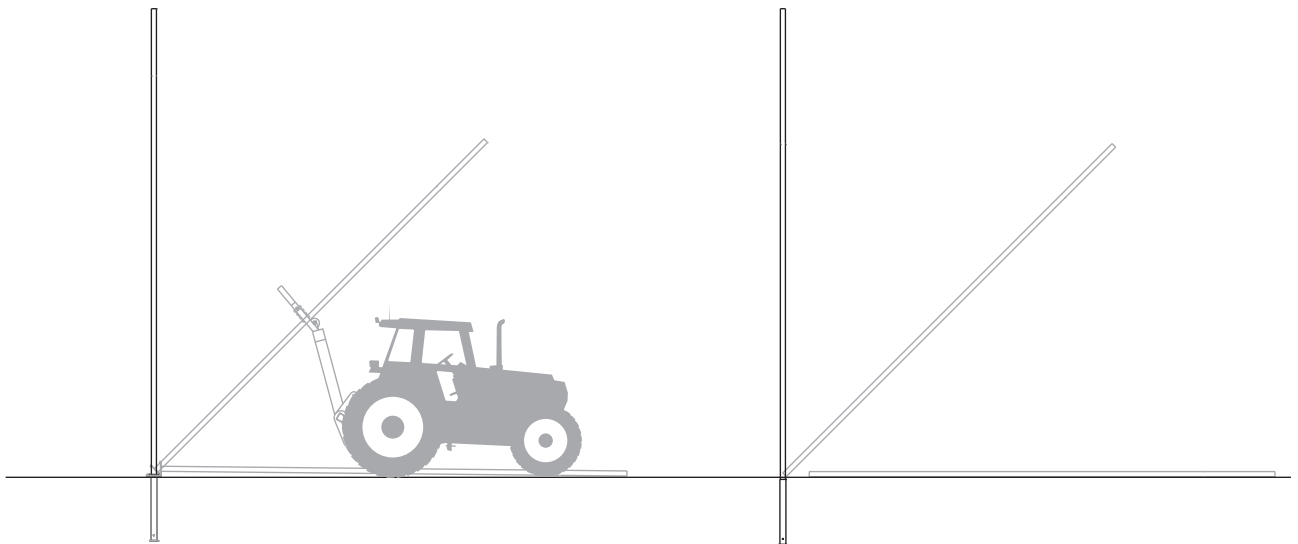

4. Hinged Rugby with Rugby Lifter

5. Socketed Rugby

7. Rugby posts are best and most easily moved with the aid of the **Rugby Storage Trolley**. The trolley is designed to transport and store all the components required for half a set of posts. This means two trolleys will be required for one full set of posts.

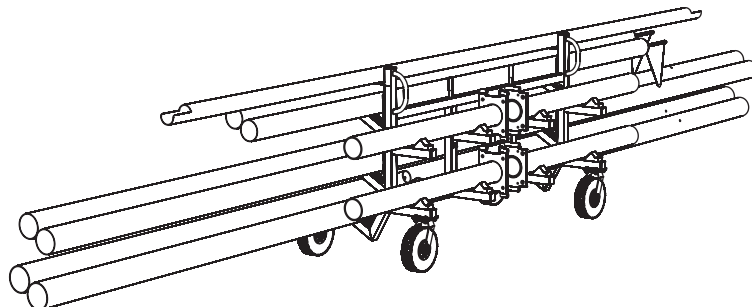

7. Rugby Storage Trolley

Hockey

1. We strongly recommend that wheels are used to transport hockey goals. Otherwise, goals should only be lifted with a minimum of four competent persons.
2. Only devices specified by the manufacturer must be used to manoeuvre goals.
3. Hockey goals with **Rear Fitted Wheels** must be tipped back on to the wheels using four competent persons, in each corner of the goal. The sideframes and top rear support bars are integral parts of the goal for supporting the netting and are not to be used as the principle method for tipping the goal.
4. When using the **Front Flip-Over Wheels**, the lifting handles fitted to the goal are to be used when flipping the wheel into place. This requires two people on either side (one to lift, one to flip).
5. For **Integrally Weighted Hockey** goals, two competent persons are required to move the goal. Standing behind the posts, put one foot on the wheel to stabilise and lean the goal back. Manoeuvre the goal into the desired location and carefully let the goal down, making sure not to drop it.
6. Weighted Hockey goals require a minimum pitch run off area of 2 metres and must not be stored with the back of the goal against a surface. Space must be available to allow the goal to be tipped back.



3. Rear Fitted Wheels

4. Front Flip-Over Wheels

5. Weighted Hockey

7. **Fence Folding Hockey** goals require two competent persons to fold the goal flat. Standing at each post, apply an even force to move the goal until flat against the wall.
8. **Hockey Pitch Divider Pads** and **Indoor Sideboards** are best moved with the aid of the **Hockey Rebound Storage Trolley**. The trolley is designed to store and transport enough Pitch Divider Pads for a single pitch surround and half a set of Indoor Hockey Sideboards. Please do not exceed the recommended 400kg maximum weight stated on the trolley.

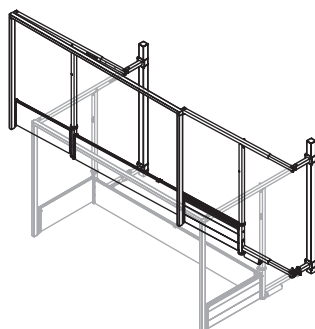

7. Fence Folding Goals

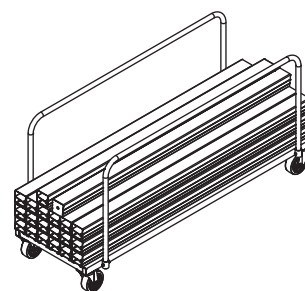

8. Hockey Rebound Storage Trolley

Tennis

1. **Freestanding Tennis Posts** should only be moved by means of the **Freestanding Tennis Trolley**, unless the posts have been completely dismantled.
2. A minimum of two trolleys must be used per set of posts.
3. Trolleys should only be used for moving posts. Posts should not be stored on trolleys at any time.
4. Only use trolleys that were specifically made for transporting tennis posts.
5. Two competent persons are required to lift each end of posts on to the trolley. Use fixing bolts to secure posts on trolley before attempting to move.
6. Care should be taken not to over tension the net as this can potentially cause each end of a freestanding tennis post to lift and render the posts unstable.

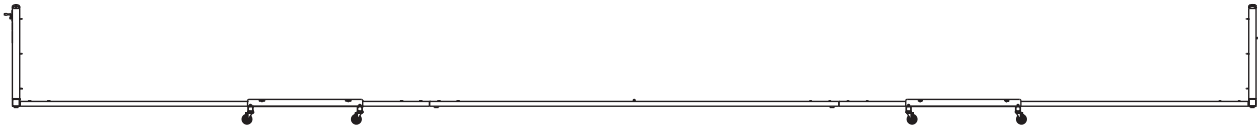

1. Freestanding Tennis

7. **Wheelaway Freestanding Tennis Posts** require one competent person at each end of the system to manoeuvre. Place one foot on the bottom wheel to anchor the posts and pull the top of the upright slowly towards you until resting on the top wheels.
8. Before moving **Wheelaway Weighted Tennis Posts**, the net must be removed from the system. Place one foot on a wheel to anchor the posts and tip the system back until the post is just past the horizontal, or wherever is most comfortable and stable.
9. We recommend the net winder handle be removed if the posts are left unsupervised.

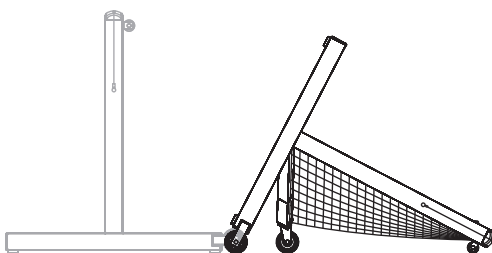

7. Wheelaway Freestanding Tennis

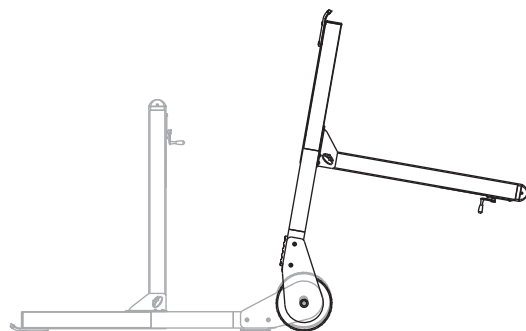

8. Wheelaway Weighted Tennis

Netball

1. All Netball posts must be laid down and stored in a secure covered location when not in use.
2. **Freestanding Netball Posts** must only be wheeled in a pushing motion from the top of the post.
3. **Socketed Netball Posts** require 2 people to lift from socket and move.

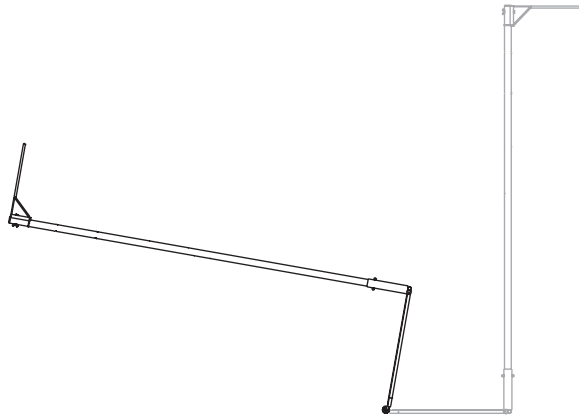

2. Freestanding Netball

Team Shelters

1. **Aluminium Team Shelters** are designed to be permanently fixed to an appropriately prepared surface.
2. The correct amount of fixings must be used depending on the size of the shelter.
3. When moving shelters, the correct number of competent persons are required, as stated in the instructions.
4. Shelters should never be left unsecured.

Pitch Dividers

1. **Pitch Divider Systems** are designed to have wire as a permanent fixture and this should not be removed on a regular basis.
2. If wire is required to be taken down, release the pressure on the wire, detach from anchor post, coil and tie it off, then store in pouch with netting.
3. Pitch divider netting is retractable and should be stored in a storage pouch.
4. The netting must be retracted using a 'pull and draw' system. This is achieved by standing at the storage end of the system and by slowly pulling the net inwards until all the netting has been gathered. Do not walk with it from one end to another as this will cause the netting to become entangled and put excess stress on the clips used to suspend the netting.

Background

In the UK, standards for goal posts and nets for a variety of sports are set by the Comité de Européen Normalisation, which has been in existence since 1989. Other standards have also been set in more recent times by the BSI, specifically for junior, mini, small-sided football and futsal. Harrod UK have been representatives on the CEN committee since 1989, the FA Guidelines Committee since 2003 and the BS 8462/8461 Committee since 2005.

Purpose of CEN

To normalise and raise standards for goal posts throughout the European community. A committee whose aim is to ensure all equipment is manufactured to the highest standard, and to create awareness of the highest level of responsibility bestowed upon the authorities responsible for the equipment and its use.

Implications

Providers of sports equipment have a responsibility to supply equipment that is fit for purpose and above all, safe to use at all times. Equipment that conforms to BSEN and BS standards have to be independently tested for both strength and stability by a registered testing house and manufacturers are obliged to produce copies of these certificates on demand.

At Harrod UK we have long since identified the need for “bulletproof” goals and have developed a unique range of integrally weighted goals. These goals are safe to use at all times, require no further anchorage and have been widely acknowledged at the SAPCA and Sports College Conferences as the safest metal goal available in the marketplace today. The continuing FA campaign highlights the responsibilities of pitch providers to ensure they only use goals that conform, and we cannot emphasise strongly enough that end users have the ultimate accountability in this respect.

Official Goal Sizes

Type of Goal	Internal Sizes (mm)	Appropriate Specification	Strength Test (kg)	Stability Test (kg)	Amount of ANC-005* Required (per goal)
Senior (Full Size)	7320 x 2440	BS EN 748:2013	180	110	6
Youth Football	6440 x 2130	BS 8462:2012	180	110	6
Mini Soccer	3660 x 1830	BS 8462:2012	80	70	6
Small-Sided	4880 x 1830	BS 8462:2012	80	70	6
Small-Sided (Gross mass of 18kg or more)	4880 x 1220 3660 x 1220 2440 x 1220	BS 8462:2012	80	70	4
Futsal	3000 x 2000 x 2000	BS 8462:2012	180	110	6
Hockey	3660 x 2130	BS EN 750:2004	180	110	10

*ANC-005 is a counterbalance type weight anchor used for anchoring freestanding goal posts

Anchorage: To achieve the above stability test: socketed goals must be installed with the correct amount of concrete around the socket; and freestanding goals should be anchored in the correct manner. Full details of Harrod UK anchorage systems are available at:

www.harrod.uk.com